

■ SUPER HEAVY DUTY • SHD SERIES

SHD64520

12 V Truck & Commercial Vehicle Starter Battery

SEALED • MAINTENANCE-FREE

SILVER CALCIUM

Super Heavy Duty

12 v

NOMINAL VOLTAGE

145 Ah

CAPACITY (20HR)

800 A

COLD CRANK (EN)



FIG.1 – SHD64520 / F51 CASE

01 High Cranking Power

Calcium-alloy plates hold strong start-up output, even in extreme heat.

02 Maintenance-Free

Sealed dual-cover labyrinth design — no topping up, no electrolyte loss.

03 Vibration Resistant

Envelope separators wrap plates to survive road shock and resist shorting.

04 Low Self-Discharge

Forged Pb-Ca grids cut gassing and water use for longer shelf life.

■ SPECIFICATIONS

ELECTRICAL

Nominal Voltage	12 V (6 cells)
Capacity – C20 (20HR)	145 Ah
Cold Crank – CCA (EN)	800 A
Reserve Capacity	~ 240 min *
Technology	Flooded • Silver Calcium
Maintenance	Free (sealed, no topping)

PHYSICAL

Length (L)	508 mm *
Width (W)	222 mm *
Height w/ terminals (H)	220 mm *
Weight (filled)	~ 35.8 kg *
Container / Cover	Polypropylene (PP)
Terminal / Vent	Std. cone • flame arrestor

* Indicative – typical for the N120 / F51 (64520) class. Confirm against the product label before fitment.

■ CROSS-REFERENCE

N120	F51	MF135F51R	64589	63530
64020	62034	K8	EE1403	

■ DIMENSIONS

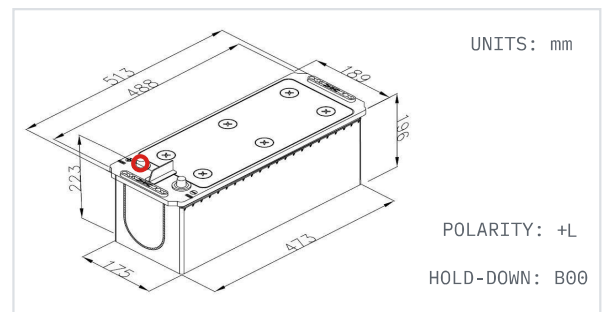

■ APPLICATIONS

Trucks & HGV	Buses & Coaches	
Buses & Coaches	Construction	Agricultural
Boats		

2-Year Limited Warranty

From date of purchase. Manufactured to EN / IEC standards under an ISO 9001 quality system.

EN / IEC

ISO 9001